

## CinemaSnap

### HI RES MATRIX WHITE FIXED FRAME - FLOCKE FINISH



High Colour Saturation

Low Colour Saturation



High Resolution

Low Resolution

A premium projection screen material that is specifically designed to enhance the home theatre experience.

Through improved resolution technology and utilising state of the art optical structures on the front of the surface and a light-tight grey backing, the new Matrix White surface in conjunction with the CinemaSnap fixed frame system is today's ultimate screen for LCD or DLP Projectors.



#### HI RES MATRIX WHITE IMPROVES

- Resolution
- Colour Saturation
- Anti-Hot Spotting
- Brightness Levels.
- Off Axis Viewing

Hi Res Matrix White has a unique micro-textured surface which displays a sharper resolution level and the grey backing allows no projected light to pass through the fabric, therefore increasing brightness levels over the standard matt white fabric, through improved reflection of the projected light.

#### PRODUCT FEATURES

- Hidden mounting system
- Powder coated aluminium frame
- Bevelled frame edges
- Unique SNAP surface fixing system
- Surface under constant tension for optimum lay flat
- Includes wall mounting brackets
- Custom Sizes and format ratios available
- Flocke frame optional

Tech Drawing  
Hyperlink :

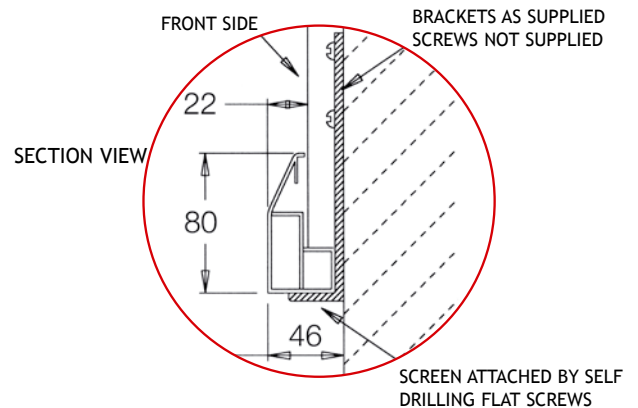

#### Notes:

- The CinemaSnap frame system utilises the structure of the wall to provide frame rigidly. If you intend to not use the wall but some other method of mounting please contact the sales office for advice on any engineering alterations that may be required.
- Custom sizes & formats available upon request

This product is the only suitable screen to be used in conjunction with a short throw projector, for the best results using a short throw projector we recommend using the CinemaSnap range.

For more information on the Hi Res Matrix CinemaSnap please see our website or click here.



## CinemaSnap

### HI RES MATRIX WHITE FIXED FRAME - FLOCKE FINISH

Setting the benchmark for perfect lay flat and ease of installation, this fixed screen system is designed to complement modern home theatre design, utilising a dedicated wall space.

Easy to install and never requires re-tensioning of the screen surface!



Item No	Inch Diagonal	Image Size mm	Format	Weight kg
1207216	72"	1100 x 1465	Video 4:3	16
1208416	84"	1280 x 1705	Video 4:3	17
1209616	96"	1460 x 1950	Video 4:3	18
1210016	100"	1525 x 2035	Video 4:3	19
1211516	115"	1755 x 2340	Video 4:3	22
1212016	120"	1830 x 2440	Video 4:3	23
1213016	130"	1980 x 2640	Video 4:3	26
1207226	72"	895 x 1595	HDTV 16:9	13
1208426	84"	1046 x 1860	HDTV 16:9	16
1209226	92"	1145 x 2035	HDTV 16:9	17
1209626	96"	1195 x 2125	HDTV 16:9	18
1210026	100"	1245 x 2215	HDTV 16:9	19
1211026	110"	1370 x 2435	HDTV 16:9	21
1211526	115"	1430 x 2545	HDTV 16:9	22
1212526	125"	1555 x 2770	HDTV 16:9	24
1213026	130"	1615 x 2880	HDTV 16:9	25
1213526	135"	1680 x 2990	HDTV 16:9	26
1214026	140"	1740 x 3100	HDTV 16:9	27
1215026	150"	1865 x 3320	HDTV 16:9	29
1207266	72"	970 x 1550	16:10	13
1208466	84"	1130 x 1810	16:10	16
1209266	92"	1240 x 1980	16:10	17
1209666	96"	1295 x 2070	16:10	18
1210066	100"	1345 x 2155	16:10	19
1211066	110"	1480 x 2370	16:10	21
1212066	120"	1615 x 2585	16:10	23
1213066	130"	1750 x 2800	16:10	24
1214066	140"	1884 x 3015	16:10	27
1215066	150"	2020 x 3015	16:10	29

Item No	Inch Diagonal	Image Size mm	Format	Weight kg
1208446	84"	835 x 1965	Cinemascope 2.35:1	18
1209246	92"	915 x 2155	Cinemascope 2.35:1	19
1209646	96"	955 x 2245	Cinemascope 2.35:1	20
1210046	100"	995 x 2340	Cinemascope 2.35:1	22
1211046	110"	1095 x 2575	Cinemascope 2.35:1	23
1212046	120"	1195 x 2810	Cinemascope 2.35:1	25
1213046	130"	1295 x 3054	Cinemascope 2.35:1	26
1214046	140"	1395 x 3280	Cinemascope 2.35:1	28
1215046	150"	1495 x 3515	Cinemascope 2.35:1	30
1216046	160"	1595 x 3745	Cinemascope 2.35:1	32
1217046	170"	1695 x 3980	Cinemascope 2.35:1	33
1218046	180"	1790 x 4215	Cinemascope 2.35:1	34

#### Notes:

- The CinemaSnap frame system utilises the structure of the wall to provide frame rigidity. If you intend to not use the wall but some other method of mounting please contact the sales office for advice on any engineering alterations that may be required.
- Custom sizes & formats available upon request

This product is the only suitable screen to be used in conjunction with a short throw projector, for the best results using a short throw projector we recommend using the CinemaSnap range.



For more information on the Hi Res Matrix CinemaSnap please see our website or click here.